



MANORSHI ELECTRONICS CO.,LTD

PRODUCT SPECIFICATION

Product Name: SMD Buzzer

Part Number: SM10ET03AV3.6R18SH

Document No: _____

Date: 2021.05.31

| | | |
|------------|------------|-------------|
| DRAWING BY | CHECKED BY | APPROVED BY |
| CHEN YUAN | YUE QIN | JIN LI |



MANORSHI ELECTRONICS CO.,LTD

1.1.ELECTRICAL AND ACOUSTICAL SPECIFICATION

| No. | Item | Unit | Specifications |
|------|-----------------------------|--------------------|----------------|
| 1-1 | Rated Voltage (Square Wave) | V | 3.6 |
| 1-2 | Operating Voltage | V | 2-5 |
| 1-3 | * Rated Current (Max) | mA | 90 |
| 1-4 | * Min Sound Output at 10cm | dB | 85 |
| 1-5 | * Resonant Frequency | Hz | 2830 |
| 1-6 | Coil Resistance | Ω | 18 ± 3 |
| 1-7 | Operating Temperature | $^{\circ}\text{C}$ | -30~+70 |
| 1-8 | Storage Temperature | $^{\circ}\text{C}$ | -40~+85 |
| 1-9 | Weight | g | 0.6 |
| 1-10 | Housing Material | LCP (Black) | |
| 1-11 | Lead Pin Material | Brass | |

* Value Applying at Rated Voltage (resonant frequency, 1/2 duty, square wave)

2.ENVIRONMENTAL TEST

| No. | Item | Specifications |
|-----|-----------------------|--|
| 2-1 | Storage in High temp. | Storage in $+85^{\circ}\text{C} \pm 2^{\circ}\text{C}$ test box for 96 hours, then expose to the room temperature for 2 hours without applying power. |
| 2-2 | Storage in Low temp. | Storage in $-40^{\circ}\text{C} \pm 2^{\circ}\text{C}$ test box for 96 hours, then expose to the room temperature for 2 hours without applying power. |
| 2-3 | Storage in Humidity | Storage in $+40^{\circ}\text{C} \pm 2^{\circ}\text{C}$ 90-95%RH test box for 96 hours, then expose to the room temperature for 2 hours without applying power. |
| 2-4 | Thermal cycle test. | <p>Make this test for 5 cycles without applying power, then expose to the room temperature for 2 hours.</p> |

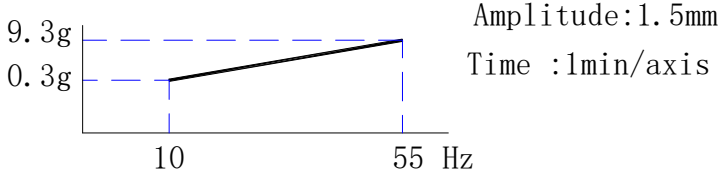
| | | |
|---|--------------------|--|
| 2-5 | Vibration test |  <p>Amplitude: 1.5mm Time : 1min/axis</p> <p>Make this test for the directions of X,Y, Z for 2 hours each (total 6 hours).</p> |
| 2-6 | Drop test | Free drop a unit from the height 100cm to the surface of 10mm thick board ,three directions(X,Y,Z). |
| 2-7 | Solderability test | Soldering temp.: $260 \pm 5^\circ\text{C}$ Heat applying time: $3 \pm 0.5\text{sec}$. |
| <p>PASS CRITERION :</p> <p>After these tests , the change of S.P.L shall be within $\pm 5 \text{ dB}$.</p> | | |

3.MEASURING METHOD(BUZZER MODE)

3-1 .Test Condition

3-1-1.STANDARD

Temperature : $25 \pm 3^\circ\text{C}$

Relative humidity : 60% ~ 70%,

Atmospheric pressure : 860mbar to 1060mbar

3-1-2.JUDGEMENT

Temperature : $15 \sim 35^\circ\text{C}$

Relative humidity : 45% ~ 85%,

Atmospheric pressure : 860mbar to 1060mbar.

3-2 . Standard Test Fixture

1.rated Voltage(Square wave):3.6V

2.Resonant Frequency:2830Hz

3. Standard Drive Circuit:

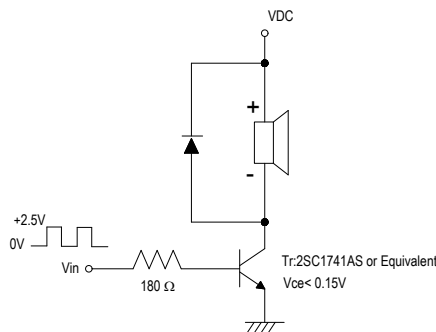

4. Standard test fixture:

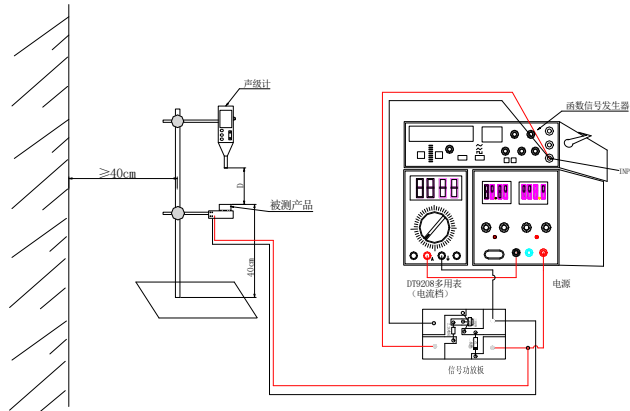

4.DIMENSIONS

Unless otherwise specified,tolerance:±0.5(unit:mm)

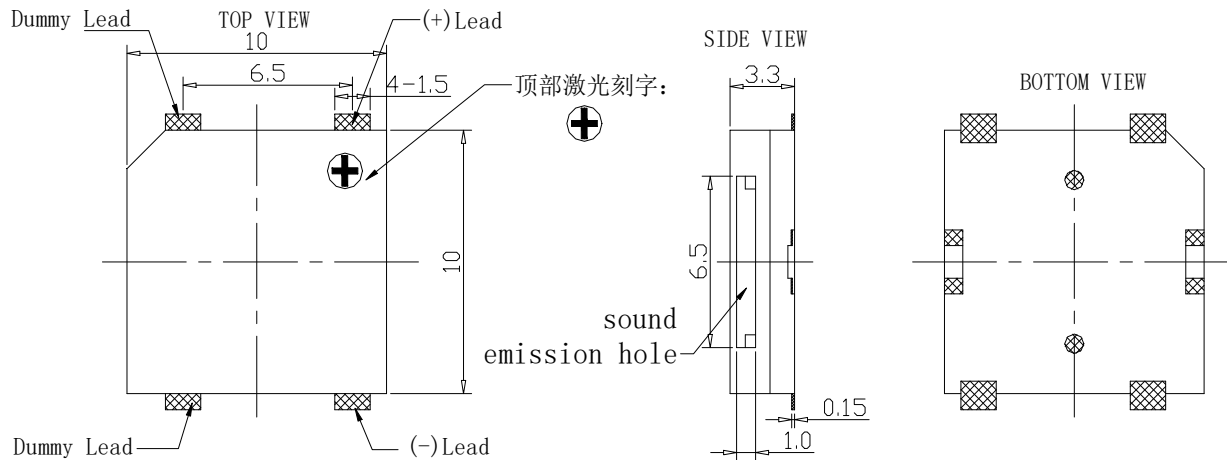

| | |
|--------------------------------------|---------|
| Cadmium(Cd)/Cadmium Compounds | ≤100ppm |
| Lead (Pb) / Lead Compounds | ≤800ppm |
| Mercury (Hg) Mercury Compounds | ≤800ppm |
| Hexavalent-Chromium (Cr6+) Compounds | ≤800ppm |
| PBB | ≤800ppm |
| PBDE | ≤800ppm |

- 1) All parts must be meet to ROHS.
- 2) Reflow solder allowed, wash not allowed.

5.PACKING

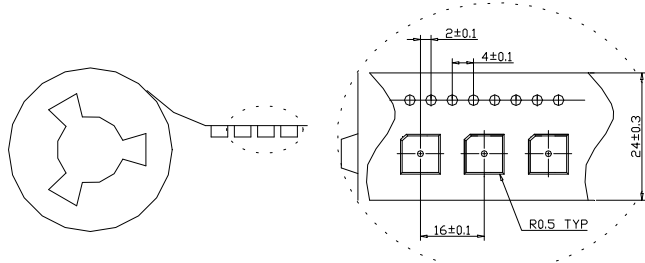

1000PCS/CARRUER REEK; 每卷装1000只

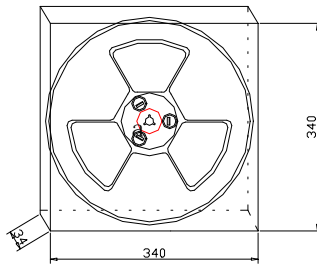

1ROLL CARRIER REEL/INNER BOX; 1卷放入一内盒

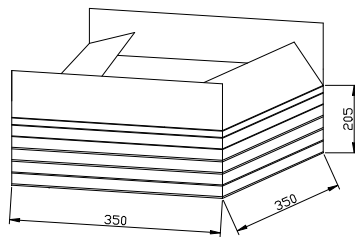

5000PCS/CTN 每箱放5000只(5只内盒)